

DC/DC Digital Adjustable Power Supply User Manual

Model D10PA

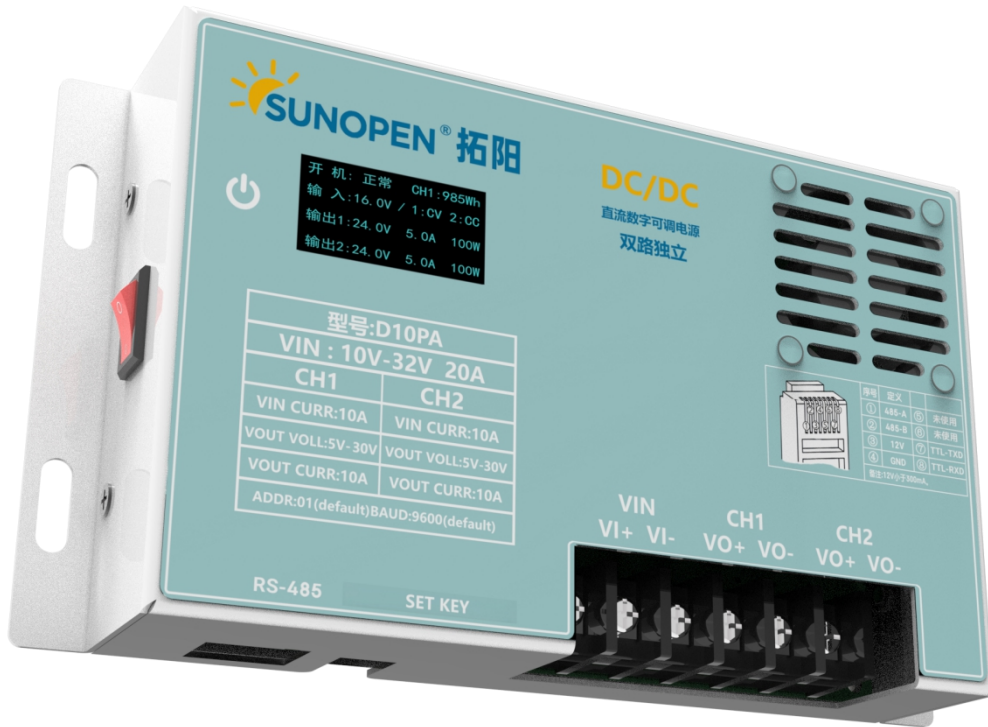





Sept-dwon & Boost Type / Dual independent Channels



Manual Version: V1.0 Subject to change without notice. Contact sales for the latest e-document

Thank you for choosing our product!

Safety Instructions

-  1、 As the operating voltage of this controller exceeds the safe voltage for human contact, please thoroughly read the manual and complete safety operation training before handling this controller.
before operating this controller.
-  2、 There are no user-serviceable parts inside the controller. Do not disassemble or attempt repairs yourself.
-  3、 Install the controller indoors to avoid exposing components and prevent water ingress into the controller.
-  4、 Install the controller in a well-ventilated area, as the heat sink will become very hot during operation.
-  5、 It is recommended to install an appropriate fuse or circuit breaker externally on the controller.
-  6、 Before installing or adjusting the controller wiring, ensure the load, input power supply, and fuses or circuit breakers near the battery terminals are disconnected.
-  7、 After installation, inspect all wiring connections to ensure they are secure and prevent potential hazards caused by loose connections leading to heat buildup.



Warning: Indicates a hazardous operation. Ensure all safety



preparations are completed before proceeding.

Caution: Indicates destructive consequences if performed.



Tip: Indicates recommendations and suggestions for the operator.

Table of Contents

1. Product Introduction.....	1
1.1. Product Overview.....	4
1.2. Product Features.....	4
1.3. Appearance and Interface Description.....	5
2. Technical Parameters.....	6
3. Power-On/Off Instructions.....	6
4. TTL Communication, RS485 Communication, External 12V Output, Interface Pin Definitions.....	7
5. Fan Temperature Control.....	7
6. Troubleshooting.....	7
7. Display Interface Introduction.....	8
8. Product Installation.....	10
8.1. Installation Notes.....	10
8.2. Installation Steps.....	10
9. Protection Functions.....	11
10. System Maintenance.....	11
11. Product Dimension Diagram.....	11
12. Communication Protocol.....	12
12.1. Basic Communication Configuration.....	12
12.2. Message Addresses.....	12
13. Accessory Details Table.....	14
13.1. Fault Table.....	14
14. System Wiring Diagram.....	14

1. Product Overview

1.1 Product Overview

The D10PA series controller is a four-switch buck-boost DC-DC power management controller featuring strong anti-interference capability and ultra-low ripple output.

- Wide input voltage range: 10V to 32V; wide output voltage range: 5.0V to 30V. Each channel supports up to 10A input/output.
- High efficiency: 95%–99%
- Under-voltage protection, over-temperature protection, output short-circuit protection, intelligent thermal fan control
- Low ripple output <50mV, strong anti-interference capability, stable load start-up
- Digitally adjustable CC/CV with 0.1A current steps and 0.1V voltage steps
- The controller incorporates comprehensive software and hardware fault detection and protection functions to minimize damage to product components caused by installation errors or system failures.

damage to product components.

This product is dedicated to providing reliable and stable power supply for precision instruments sensitive to power supply ripple!

1.2 Product Features

- High-efficiency synchronous boost conversion with efficiency exceeding 95%.
- • Supports CV and CC modes.
- • Supports charging for various battery types including 12V/24V sealed, gel, open-vented, lithium batteries, and custom types.
- • Supports adjustable charging voltage; automatically switches to constant voltage charging upon full charge (user-configurable charging voltage).
- • Intelligent fan start/stop.
- • Supports multiple load operating modes.
- • Supports starting capacitive and inductive loads.
- • Comprehensive protection mechanisms against overvoltage, overcurrent, overload, overtemperature, short circuit, and constant-voltage charging.
- • Utilizes high-quality aluminum heat sinks, air cooling, and high-temperature derating to ensure reliable and efficient operation in diverse environments.

1.3 Appearance and Interface Description

Front Panel Interface Overview

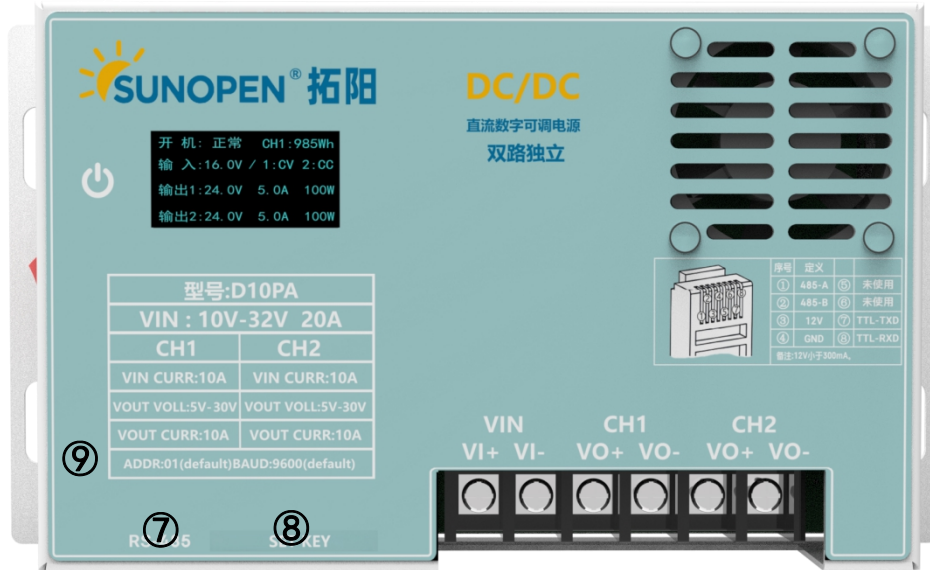

Serial Number	Function Description	Remarks
①	Display Interface	See Display Section for Details
②	Start Button	Side Toggle Switch
③	Power Input Interface	
④	Channel 1 Output Interface	
⑤	Channel 2 Output Interface	
⑥	Fan outlet	Do Not Block
⑦	RS-485/Bluetooth/4G Interface	RJ45 Ethernet Port
⑧	Digital Encoder	
⑨	Grounding screw hole positions	

2. Technical Specifications

Product Model	D10PA (Dual Channel)	
Input Voltage	10V~32V	
Static Power Consumption	≤10mA (output stopped)	
Maximum Input Current	20A	
Maximum Power	480W	
Channels	Channel One	Channel 2
Operating Mode	Buck-Boost	Boost-Buck
Front-End/Back-End Maximum Current Limit	10A	10A
System Maximum Voltage Rating	40V (±2%) Overvoltage will damage the system	40V (±2%) Overvoltage will damage the system
Conversion Efficiency	90%~99%	90%~99%
Supports lithium battery charging	Set CC/CV before charging	Set CC/CV before charging
Full-load ripple	<±50mV	<±50mV
Adjustable output voltage	5V~30V	5V~30V
CC step	0.1A	0.1A
CV Step	0.1V	0.1V
Load Power Loss Calculation	√	√
Temperature Protection	√	√
Overload/Short Circuit Protection	√	√
TTL Communication	√	√
RS485 Communication	√	√
External 12V Power Supply (<300mA)	√	√
Display	√	√
Bluetooth Support (External Speaker Optional)	√	√
Supports Ethernet (external expansion, optional)	√	√
Auto-save settings	√	√
Stepless fan speed control	√	√
Supported baud rate types	4800/9600/14400/19200/38400/56000/57600/115200 (Default 9600; requires host computer configuration to change)	
Backlight Adjustment Function	10S~200S (0 = Always On, currently unsupported)	
Protection Functions	Input overvoltage/undervoltage protection, input reverse polarity protection, output short-circuit protection, nighttime reverse charging protection, input power limit protection, over-temperature protection, load short-circuit protection, load overload protection, battery overvoltage/over-discharge protection	
Operating Temperature Range	-35°C to 65°C (No derating required below 45°C in well-ventilated conditions)	
Protection Rating	IP32	
Cooling Method	Natural convection cooling, forced air cooling	
Dimensions	Dimensions: 94.5 x 170 x 34 mm	
Weight	0.36 kg	

3. DIP Switch and Power Operation Instructions

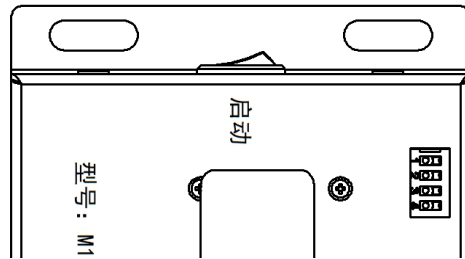

① To power on the device, slide the switch left to

4. Pin Definitions for TTL Communication, RS485 Communication, and External 12V Output Interface

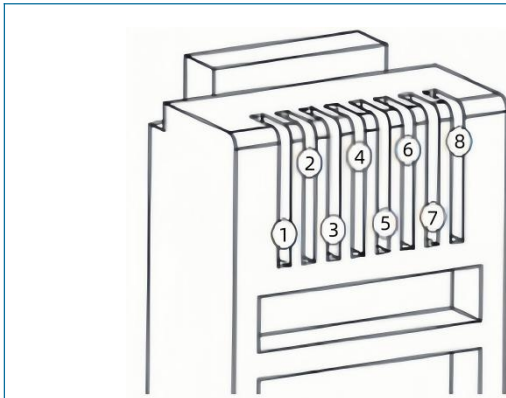

Serial Number	Definition
①	485-A
②	485-B
③	12V
④	GND
⑤	Not Used
⑥	Not used
⑦	TTL-TXD
⑧	TTL-RXD

Note: Maximum 300mA current at 12V. Exceeding this may damage the interface with some probability.

5. Fan Temperature Control

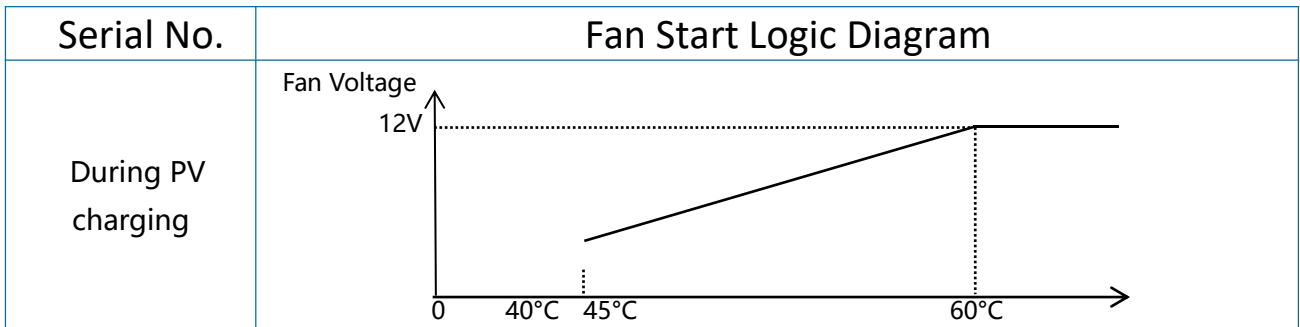

6. Common Issues and Solutions

Symptom	Solution
Indicator lights and LCD screen do not illuminate	Check if the battery and solar panel connections are correct
Input voltage present, but no output voltage at the output terminals	Check if input voltage is overvoltage or undervoltage. Alternatively, check if output is short-circuited
Remote control output voltage/current unresponsive	Remotely disconnect the output before configuration
Load fails to start certain loads	Adjust the output current via the host computer to accommodate different external loads
No response when connecting the battery	1、 Was the fuse damaged due to reverse connection last time? Replace the fuse or contact the manufacturer for repair.
Fan not spinning	1、 Check for foreign objects blocking the fan. Clean the air duct regularly to remove debris. 2、 If the fan still does not operate after clearing debris, contact after-sales service for fan replacement. 3、 Is silent mode enabled?

7. Display Interface Overview

7.1.1 Channel 1 Settings Display Interface (Chinese)

	① Channel 1 Input Undervoltage Protection Setting	Input < 10V disables output; current hysteresis set to 1V. Input > 11V triggers restart
	② Channel 1 Output Voltage Setting	Set output to 24V
	③ Channel 1 Output Current Setting	Set constant current to 5A
	④ Channel 1 Input Voltage Hysteresis Setting	After input undervoltage, restart output when input > 11V

7.1.2 Channel Two Display Interface (Chinese)

	① Channel 2 Input Undervoltage Protection Setting	Input < 10V disables output; current hysteresis set to 1V. Input > 11V triggers restart
	② Channel 2 Output Constant Voltage Setting	Set output to 24V

	③ Channel 2 Output Current Setting	Set constant current to 5A
	④ Channel 2 Input Voltage Hysteresis Setting	After input undervoltage, restart output when input > 11V

7.1.3 Power-on startup display interface (Chinese)

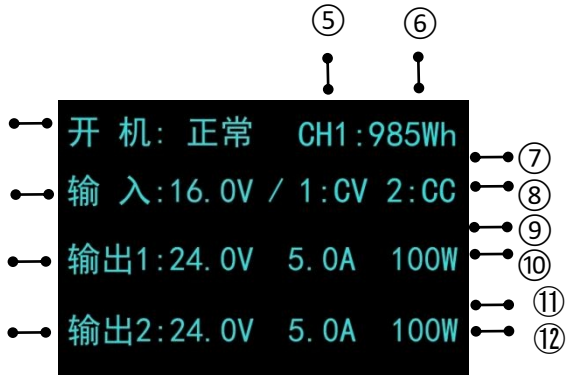
	① Power-on status	Display: Normal, Overvoltage, Overcurrent, Fault, Undervoltage, etc.
	② Input Voltage	Display: Current system input voltage 16V
	③ Channel 1 Output Voltage	Display: Current system Channel 1 output 24V
	④ Channel 2 Output Voltage	Displays the current system Channel 2 output voltage: 24V
	⑤ Channel 1 Flow Rate Statistics	Displays historical discharge volume/single discharge volume for Channel 1
	⑥ Channel 2 flow statistics	Display historical discharge volume/single discharge volume for Channel 2
	⑦ Channel 1: Constant voltage/constant current mode	Display Channel 1 Current Output Mode Constant Voltage State
	⑧ Channel 2 Constant Voltage Constant Current Mode	Display Channel 2 Current Output Mode Constant Current State
	⑨ Channel 1 Output Current	Displaying Channel 1's current output
	⑩ Channel 1 Output Power	Display Channel 1's current output power
	⑪ Channel 2 Output Current	Display Channel 2's current output current
	⑫ Channel 2 output power	Display Channel 2 current output power

7.2.1 Channel Channel 1 Settings Display Interface (English)

	① Channel 1 Input Undervoltage Protection Setting	Input < 10V disables output; current hysteresis set to 1V. Input > 11V triggers restart
	② Channel 1 Output Voltage Setting	Set output to 24V
	③ Channel 1 Output Current Setting	Set constant current to 5A
	④ Channel 1 Input Voltage Hysteresis Setting	After input undervoltage, restart output when input > 11V

7.2.2 Channel Two Display Interface (English)

	① Channel 2 Input Undervoltage Protection Setting	Input < 10V disables output; current hysteresis set to 1V. Input > 11V triggers restart
	② Channel 2 Output Constant Voltage Setting	Set output to 24V
	③ Channel 2 Output Current Setting	Set constant current to 5A
	④ Channel 2 Input Voltage Hysteresis Setting	After input undervoltage, restart output when input > 11V

7.2.3 Power-On Startup Display Interface (English)

	① Power-on status	Display: OK, OV, OV, ERR, UV, etc.
	② Input Voltage	Displays current system input voltage: 16V
	③ Channel 1 Output Voltage	Display: Current system Channel 1 output 24V
	④ Channel 2 Output Voltage	Displays the current system Channel 2 output voltage: 24V
	⑤ Channel 1 Flow Rate Statistics	Displays historical discharge volume/single discharge volume for Channel 1
	⑥ Channel 2 flow statistics	Display historical discharge volume/single discharge volume for Channel 2
	⑦ Channel 1 Constant Voltage/Constant Current Mode	Display Channel 1 Current Output Mode Constant Voltage State
	⑧ Channel 2 Constant Voltage Constant Current Mode	Display Channel 2 Current Output Mode Constant Current State
	⑨ Channel 1 Output Current	Displaying Channel 1's current output
	⑩ Channel 1 Output Power	Display Channel 1's current output power
	⑪ Channel 2 Output Current	Display Channel 2's current output current
	⑫ Channel 2 output power	Display Channel 2's current output power

8. Product Installation

8.1 Installation Precautions

- Exercise extreme caution when installing batteries. Wear safety goggles when handling open-top lead-acid batteries. If battery acid comes into contact with skin, immediately rinse thoroughly with clean water.
- Avoid placing metal objects near the battery to prevent short circuits.
- Charging batteries may produce acidic gases; ensure the surrounding environment is well-ventilated.

- Batteries may produce flammable gases; keep away from sparks.
- When installing outdoors, avoid direct sunlight and rain penetration.
- Loose connections and corroded wires can cause excessive heat, melting wire insulation, igniting surrounding materials, and potentially starting fires. Ensure all terminals are securely tightened and wires
Secure wires with cable ties to prevent movement during operation, which could loosen connections.
- When connecting the system, the output voltage of the components may exceed safe human voltage levels. When handling, use insulated tools and ensure hands are dry.
- The battery terminals on the controller can connect to either a single battery or a group of batteries. Subsequent instructions in this manual apply to single-battery use but they also apply to systems using a battery bank.
- Follow the battery manufacturer's safety recommendations.
- Ground the controller's ground terminal.
- Reverse connection of the battery during installation is strictly prohibited, as it will cause irreversible damage.

8.2 Installation Procedure

Wiring and installation methods must comply with national and local electrical code requirements. Wiring specifications must be selected based on the rated current, typically at 5A/mm².

Step 1: Select Installation Location

Avoid installing the controller in areas exposed to direct sunlight, high temperatures, or potential water ingress. Ensure adequate ventilation around the controller.

Step 2: Secure Mounting Screws

Mark the installation location according to the controller's dimensions. Drill two appropriately sized mounting holes at the marked positions and secure screws into both holes.

Step 3: Secure the Controller

Align the controller's mounting holes with the two pre-installed screws, then hang the controller into place. Secure it by tightening the two screws at the bottom.

Step 4: Secure the Grounding Wire

Secure one wire to the controller's side screw. Connect the other end of the wire to the ground effectively (e.g., by burying it with a metal block attached) to divert leakage currents, static electricity, and lightning strikes into the earth.

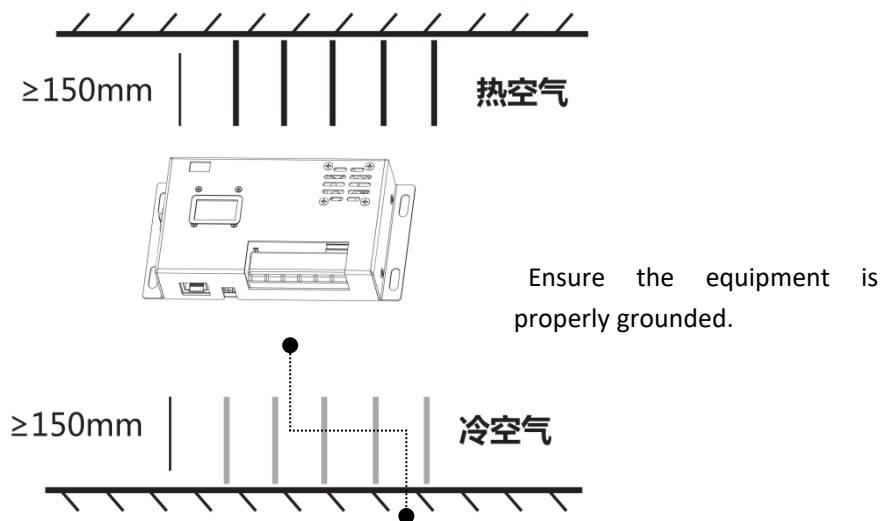

9. Protection Functions

- Equipment Over-Temperature Protection**
 When the internal temperature of the controller exceeds the set value, the fan will automatically activate. As temperature rises, fan speed increases. If temperature continues to rise even at maximum fan power, the output will automatically shut down.
- Short-Circuit Protection**
 If the output load shorts, the device will halt output; it will automatically restart after 30 seconds. This cycle repeats.
- Input Overpower Protection**
 When output power exceeds the rated power, the controller will cease output to prevent excessive current from damaging the controller.
- Input Overvoltage**
 If the input voltage is too high, the controller will automatically cut off the load output.
- Input Reverse Polarity Protection**
 If the input terminals are reversed, the controller will not be damaged. It will resume normal operation after the wiring error is corrected.
- Backflow Protection**
 If the output load is a battery, backflow will not occur, preventing controller damage.

10. System Maintenance

To ensure the controller maintains optimal performance over time, it is recommended to periodically perform the following inspections.

- When abnormal faults or error messages are detected, corrective actions should be taken promptly.
- Inspect terminals for corrosion, insulation damage, signs of overheating or burning/discoloration, and housing deformation. Repair or replace as needed.
- Inspect wires for exposure, damage, or degraded insulation; repair or replace them promptly.
- Clean any dirt, nesting insects, or corrosion promptly.

WARNING: Risk of electric shock! Ensure all power sources to the controller are disconnected before performing any inspections or operations! Unauthorized personnel must not operate the equipment.

11. Product Dimension Diagram

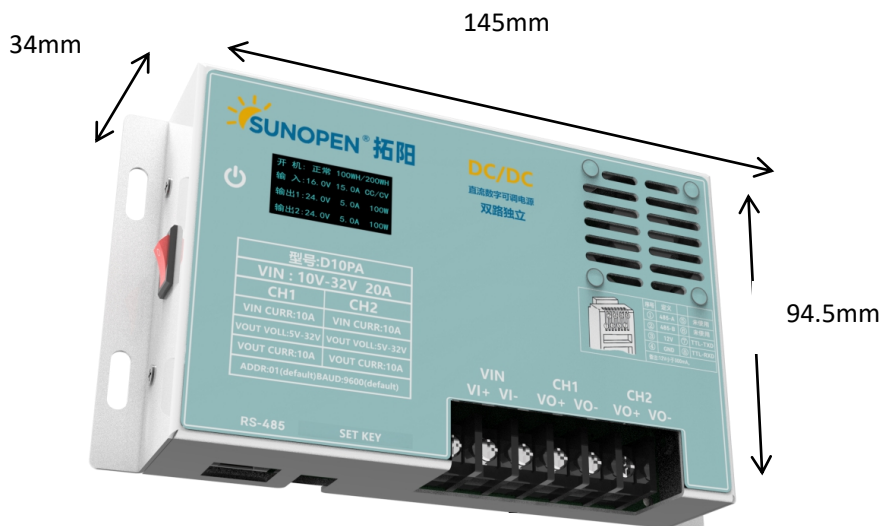

12. Communication Protocol

12.1 Basic Communication

Transmission Mode	RTU	<p>Protocol Standard/Function Code</p> <p>This communication protocol is based on the <Standard MODBUS Protocol>. The master device periodically requests data from the slave device, which receives the request command and responds with the data.</p>	0x02 Read one or more input states	Bitwise Read
Baud Rate	Default: 9600 bps		0x03 Read Holding Register	Read as a 16-bit word
Parity bit	No parity		0x04 Read a Single Register	Read as a 16-bit word
Data bits	8 bits		0x05 Write a coil status	Write bitwise
Stop bit	1 bit		0x06 Write a hold register	Write as a 16-bit word
Frame interval	Not less than 3.5 bytes Time		0x10 Write multiple hold registers	Write in 16-bit words
Frame length	200 bytes		<p>When the communication module detects an error other than a CRC error, it must send a response to the host. The most significant bit of the function code is 1; 01 indicates an invalid function code, 02 indicates an invalid data address</p> <p>03 Invalid data value 04 Service failure</p>	
Maximum slave response time	350 bytes			
Minimum host polling interval	400 bytes time			

12.2 Message Address

Register Address Table: Read corresponding function code 0x03, set corresponding function code 0x06. The addresses in the table below match those in the actual message frame and require no further offsetting or conversion.

Address (Decimal)	Meaning	Byte	Read/W rite	Example	Explanation
40000	Device Model	2	R	51221	D10PA
40001	Software Version	2	R	10	V1.0
40002	Hardware Version	2	R	10	V1.0
40003	Power-on Status	2	R	0	0: Off; 1: On
40004	Device Address	2	R	1	Device Communication Address: 01H (1~255)
40005	Fan Start Status	2	R	1	0: Off; 1: On
40006	Channel 1 Constant Current/Constant Voltage Mode	2	R	0	0:CV;1:CC
40007	Channel 2 Constant Current Constant Voltage State	2	R	0	0:CV;1:CC
40008	Channel 3 Constant Current Constant Voltage State	2	R	0	0:CV;1:CC
40009	Reserved	2	R	Unused	Reserved
40010	Reserved	2	R	Unused	Reserved

40011	Channel 1 Temperature	2	R	25	25° C (Accuracy 1° C)
40012	Channel 2 Temperature	2	R	25	25° C (Accuracy 1° C)
40013	Channel 3 Temperature	2	R	25	25° C (Accuracy 1° C)
40014	Channel 1 Historical Discharge WH High	2	R	0	
40015	Channel 1 Historical Discharge WH Low	2	R	666	666WH
40016	Channel 2 Historical Discharge WH High	2	R	0	
40017	Channel 2 Historical Discharge WH Low	2	R	666	666WH
40018	Channel 3 Historical Discharge WH High	2	R	0	
40019	Channel 3 Historical Discharge WH Low	2	R	0	
40020	System Input Voltage	2	R	2498	24.98V (Accuracy 0.01V)
40021	System Input Current	2	R	275	2.75A (Accuracy 0.01A)
40022	System Input Power	2	R	100	100W (Accuracy 1W)
40023	Channel 1 Output Voltage	2	R	1850	18.2V (Accuracy 0.01V)
40024	Channel 1 Output Current	2	R	30	3.0A (Accuracy 0.1A)
40025	Channel 1 Output Power	2	R	100	100W (Accuracy 1W)
40026	Channel 2 Output Voltage	2	R	1850	18.2V (Accuracy 0.01V)
40027	Channel 2 Output Current	2	R	30	3.0A (Accuracy 0.1A)
40028	Channel 2 Output Power	2	R	100	100W (Accuracy 1W)
40029	Channel 3 Output Voltage	2	R	1850	18.2V (Accuracy 0.01V)
40030	Channel 3 Output Current	2	R	30	3.0A (Accuracy 0.1A)
40031	Channel 3 Output Power	2	R	100	100W (Accuracy 1W)
40032	Channel 1 Fault Code	2	R	0	See Fault Table 1 for details
40033	Channel 2 Fault Code	2	R	0	See Fault Table 2 for details
40034	Channel 3 Fault Code	2	R	0	Detailed Component Fault Table 3
40035	System Fault Code	2	R	0	Detailed Component Fault Table 4
40036	Reserved	2	R	Not Used	Reserved
40037	Reserved	2	R	Unused	Reserved
40038	Chinese/English Selection	2	R/W	0	0: Chinese; 1: English
40039	Display discharge mode	2	R/W	1	1: Select total historical discharge; 0: Select single discharge since power-on
40040	Channel 1 Input Undervoltage Protection Setting	2	R/W	120	12.0V (Accuracy 0.1V)
40041	Channel 2 Input Undervoltage Protection Setting	2	R/W	240	24.0V (Accuracy 0.1V)
40042	Channel 3 Input Undervoltage Protection Setting	2	R/W	180	18.0V (Accuracy 0.1V)
40043	Channel 1 Input	2	R/W	10	1.0V (Accuracy 0.1V)

	Hysteresis Setting				
40044	Channel 2 Input Hysteresis Setting	2	R/W	10	1.0V (Accuracy 0.1V)
40045	Channel 3 Input Hysteresis Setting	2	R/W	10	1.0V (Accuracy 0.1V)
40046	Channel 1 Output Voltage Setting	2	R/W	120	12.0V (Accuracy 0.1V) (Setting takes effect after output is paused)
40047	Channel 1 Output Current Setting	2	R/W	50	5.0A (Accuracy 0.1A) (Setting takes effect after output is paused)
40048	Channel 2 Output Voltage Setting	2	R/W	120	12.0V (Accuracy 0.1V) (Setting takes effect after output is paused)
40049	Channel 2 Output Current Setting	2	R/W	50	5.0A (Accuracy 0.1A) (Setting takes effect after output is paused)
40050	Channel 3 Output Voltage Setting	2	R/W	120	12.0V (Accuracy 0.1V) (Setting takes effect after output is paused)
40051	Channel 3 Output Current Setting	2	R/W	50	5.0A (Accuracy 0.1A) (Setting takes effect after output is paused)
40052	Reserved	2	R/W	Not used	Reserved
40053	Reserved	2	R/W	Unused	Reserved
40054	Screen Off Time Setting	2	R/W	Not Used	Reserved
40055	Channel 1 Remote Start/Stop	2	R/W	1	1: Enable; 0: Disable
40056	Channel 2 Remote Start/Stop	2	R/W	1	1: Start; 0: Stop
40057	Channel 3 Remote Start/Stop	2	R/W	1	1: Start; 0: Stop
40058	Device Address Setting	2	R/W	1	Communication Address: 01H
40059	Device Baud Rate Setting	2	R/W	0	1: 9600 (Default) 0~7 (4800~115200)

13. Detailed Attachment List

13.1 Fault Table

Bit	Channel 1 Output	Value
Bit0	Channel 1 Output Overvoltage	1
Bit1	Channel 1 Output Undervoltage	2
Bit2	Channel 1 Output Overcurrent/Overload	4
Bit3	Channel 1 Output Short Circuit	8
Bit4	Channel 1 Input Overvoltage	16

Bit	Channel 2 Output	Value
Bit0	Channel 2 Output Overvoltage	1
Bit1	Channel 2 Output Undervoltage	2
Bit2	Channel 2 Output Overcurrent/Overload	4
Bit3	Channel 2 Output Short Circuit	8
Bit4	Channel 2 Input Overvoltage	16

